

ADJACENT CHANNEL INTERFERENCE REDUCTION IN OFDM SYSTEMS

Arwa Waleed Mustafa¹ and Khalid G. Samarah²

(Received: 01-May-2017, Revised: 03-Jul.-2017, Accepted: 19-Jul.-2017)

ABSTRACT

Orthogonal frequency division multiplexing (OFDM) is a promising candidate for cognitive radio transmission. OFDM supports high data rates that are robust to channel impairments. However, one of the biggest problems for OFDM transmission is high out-of-band radiation, which results from the sidelobes of the OFDM sub-carriers. These sidelobes are a source of interference to neighbouring transmissions. This paper focuses on reducing out-of-band radiation by reading and extracting the radiation power in the sidelobes. This is done by extending the time domain OFDM signal by zeros in both sides. The resulting signal is then transformed to the time domain and extended samples are removed to obtain the N -samples of time domain signal representing the out-of-band radiated signal. The resulting signal is Fourier transformed and high frequency sub-carriers are removed to obtain pilots that are inverted and added to the original OFDM data sub-carriers, resulting in reducing the Adjacent Channel Interference (ACI), which affects the adjacent systems. The added signal represents a noise signal to the desired OFDM signal that reduces the BER performance of the desired system, thus a weighing factor is applied to the added signal in order to get a better BER performance with good out-of-band radiation reduction.

Matlab/Simulink simulation is adopted to perform an assessment of the proposed technique with different weighing factors and different frequency separation between the desired signal and the adjacent one. For 0 dB attenuation on the added signal, a 10 dB reduction in out-of-band radiation is obtained, while 6 dB reduction is obtained when the weighing factor reduces the input signal power by 3 dB. BER performance is better by performing the reduction technique and depends on the frequency distance between the adjacent signal and the desired one.

KEYWORDS

OFDM, Out-of-band Radiation, Adjacent Channel Interference (ACI), Matlab/Simulink Simulation.

1. INTRODUCTION

In wireless communications, because of the nature of the propagation channel, adjacent signals in frequency are subject to be affected by interference that reduces their performance as well as increases the BER (Bit Error Rate) of the system. Therefore, to improve the system performance, wireless communication systems have to decrease the effect of interference. The wireless communication system is regulated in using the frequency spectrum by several institutes, like the ITU (International Telecommunication Union), where regulations are done over long areas and periods, whereas spectrum is accessed locally and over short periods [1]-[2].

Adjacent Channel Interference (ACI) is one of several types of interference discussed in this paper. It occurs between the signals that are close in frequency and due to several reasons that will be discussed later. As such, ACI helps engineers in deciding how the frequency bands may be allocated to different wireless communication systems.

Adjacent Channel Interference (ACI) results from adjacent systems with out-of-band radiation equal to the desired system frequency. This interference can be minimized using a strictly restricted signal bandwidth or a proper channel assignment [3]-[4].

The ACI is created by two effects:

1. The transmitter radiation due to the type of modulator and different hardware properties of the used devices extended over a larger frequency range. This out-of-band radiation is not completely suppressed, since the transmit filters are not ideal. This will affect the receiver with receiving unwanted power from the adjacent signals that are not perfectly filtered.

1. A. W. Mustafa is with Electrical Engineering Department, Mutah University, Alkarak, Jordan. Email: arwa_wr@yahoo.co.uk.

2. Kh. G. Samarah is with Electrical Engineering Department, Mutah University, Alkarak, Jordan. Email: kgsamarah@mutah.edu.jo

- At the receiver, the radiation from the desired channel is suppressed insufficiently by the receiver filter. Thus, some of the signal in the adjacent channel is passed onto the demodulator, where it acts as interference.

The main definition for ACI is that it is a power leakage from neighboring channels that introduce energy reception in the desired frequency band from the unwanted frequency. ACI limits the capacity and decreases the performance of the wireless system [5]. ACI is enhanced if the adjacent channel user is transmitting in a close range (as cellular systems) compared to the receiver while the receiver is trying to receive a BS (base station) signal on the channel. This is called near-far effect, as depicted in Figure 1. This effect can also occur if a mobile close to a base station transmits on a channel close to one being used by another mobile station has weak signal power due to its far position to BS. This problem also might occur if the base station has a problem in distinguishing the mobile user from the interference signal caused by the close adjacent channel mobile [6]-[7].

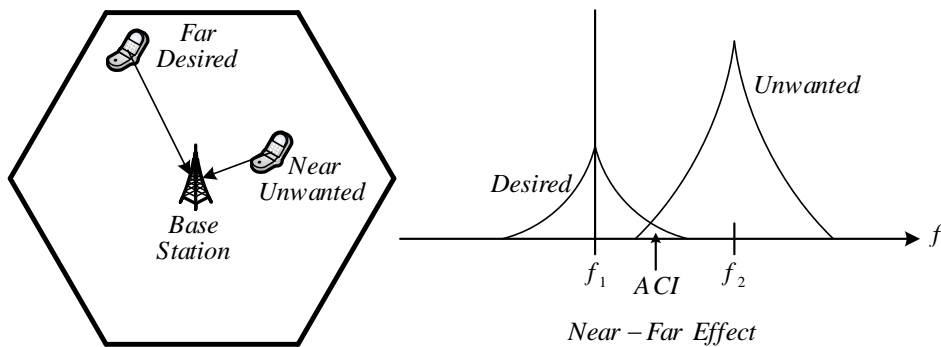

Figure 1. Near-far effect.

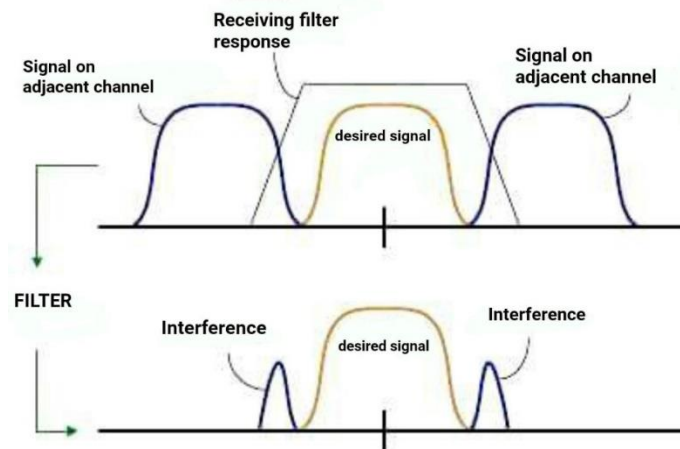

Figure 2. Imperfect receiver filtering develops ACI.

In the receiver side, additional interference from the adjacent channel will occur, since the receiver filter cannot be ideal, not completely rectangular, as in Figure 2 above. The filter will have sidelobes in the adjacent channel, causing the power from the main lobe of the transmitted interference source to affect receiver performance [8].

2. OFDM SYSTEMS

Orthogonal frequency division multiplexing (OFDM) is a technology that splits the wide band channel into smaller frequency bands called sub-carriers. These sub-carriers have to be lower than the coherent bandwidth of the multi-path propagation channel, which will convert the frequency selective fading that may affect the whole band into flat fading on each sub-carrier [9]-[11].

At the same time, OFDM converts the high data rate stream into N_d data streams (symbols). Zero padding is presented to introduce a guard band to the left and right of the frequency sub-carriers and prevent the OFDM signal from aliasing and increasing the resolution in time. The resulting

$N = N_d + N_z$ symbols modulate the frequency sub-carriers using the inverse Fourier transform. Mathematically, The k^{th} sub-carrier of the OFDM signal is described by the sinusoidal basis functions $e^{j2\pi k f_{sc} t}$. The OFDM signal is given by:

$$s(t) = \frac{1}{N} \sum_{k=-N/2}^{N/2-1} S_k e^{j2\pi k f_{sc} t} p(t), \quad k = -N/2 : N/2 - 1$$

$$p(t) = \text{rect}\left(\frac{t - T_u/2}{T_u}\right)$$
(1)

A rectangular pulse shaping filter, $p(t)$, is applied for each sub-carrier in the time domain, where f_{sc} is the sub-carrier frequency spacing, while T_u is the width of the rectangular pulse shaping filter (also called the OFDM useful symbol duration) [12]. OFDM signal given by Equation (1) can be Fourier transformed into the frequency domain by the following analysis:

$$s(t) = \frac{1}{N} \sum_{k=-N/2}^{N/2-1} S_k e^{j2\pi k f_{sc} t} p(t)$$

$$\text{fft}\{s(t)\} = \text{fft}\left\{\frac{1}{N} \sum_{k=-N/2}^{N/2-1} S_k e^{j2\pi k f_{sc} t} p(t)\right\}$$

$$S(f) = \text{fft}\{p(t)\} * \text{fft}\left\{\frac{1}{N} \sum_{k=-N/2}^{N/2-1} S_k e^{j2\pi k f_{sc} t}\right\}$$
(2)

The Fourier transform of two multiplied functions is the convolution between the Fourier transform of each function alone, where the symbol $\{*\}$ represents the convolution process [13]-[16]. OFDM signal representation in the frequency domain is given as follows:

$$S(f) = [T_u \text{sinc}(T_u f) e^{-j\pi T_u f}] * \left[\sum_{k=-N/2}^{N/2-1} S_k \cdot \delta(f - k f_{sc}) \right]$$

$$S(f) = e^{-j\pi \frac{f}{f_{sc}}} \sum_{k=-N/2}^{N/2-1} \frac{S_k}{f_{sc}} \text{sinc}\left(\frac{f - k f_{sc}}{f_{sc}}\right)$$
(3)

Due to the rectangular pulse shaping filter applied to each sub-carrier, each OFDM symbol in the frequency domain is represented by a *sinc* function. This is clearly shown in Equation (3). Due to the *sinc* shape of the OFDM symbols, large sidelobes may occur which could potentially interfere with the signal transmissions of the neighboring systems [17]-[18].

Figure 3a, shows the OFDM sub-carriers where at each sub-carrier frequency there is only one peak value of the *sinc* function and all other sub-carriers have zero values. That means that even though multiple sub-carriers coexist, they are all independent and do not influence each other. This is referred to as orthogonality [16]-[19]. Figure 3b shows the power spectral density of an OFDM modulated signal. The interference power due to the first sidelobe in the first adjacent band is shown.

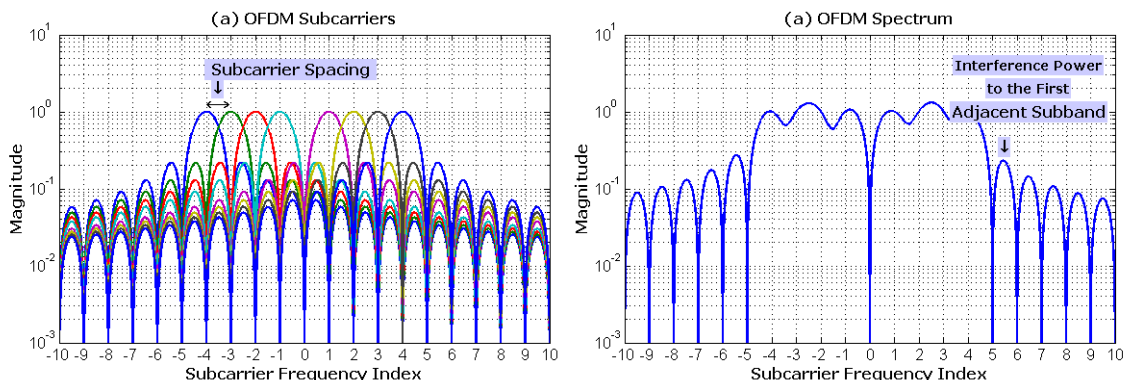

Figure 3. Orthogonality between sub-carriers.

3. MITIGATING TECHNIQUES FOR ACI

ACI in OFDM system, is a result of high out-of-band radiation that prevents the efficient use of the available spectrum [8]. Recently, four different techniques for sidelobe suppression have been proposed and are summarized next.

3.1 Guard Bands

Guard bands represent a simple technique that modulates high frequency sub-carriers with zero data. In Figure 4, one guard band is used on each side of the OFDM signal in order to reduce the out-of-band radiation. However, these guard bands act as buffer bands between the different OFDM systems and are actually wasted spectrum [20].

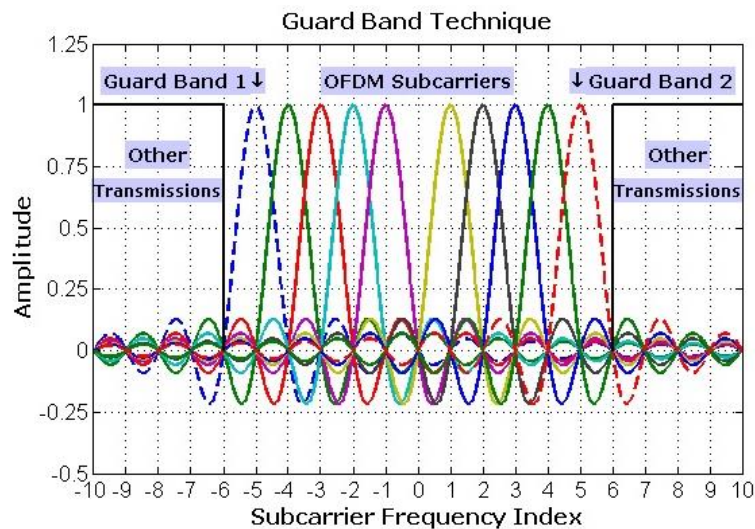

Figure 4. Guard band technique for OFDM sidelobe suppression.

The effect of GBs differs for different non-linear devices that may introduce OOB radiation due to excessive clipping of the OFDM signal. However, the reduction effect using guard bands is not significant enough and the drawback of this method is the less effective use of the available bandwidth.

3.2 Sub-carrier Weighing

This technique was proposed in [21] based on the multiplication of the used sub-carriers by sub-carrier weights which are chosen carefully to reduce the power in the sidelobes.

In Figure 5, an example of five sub-carriers is introduced and the amplitudes of individual sub-carriers are adapted to cancel each other in the optimization range, thus reducing the sidelobe power. SW method does not need to transmit any side information and is capable of reducing the OOB radiation of OFDM signals by more than 10 dB. However, it suffers from a slight loss in BER as mentioned in [21].

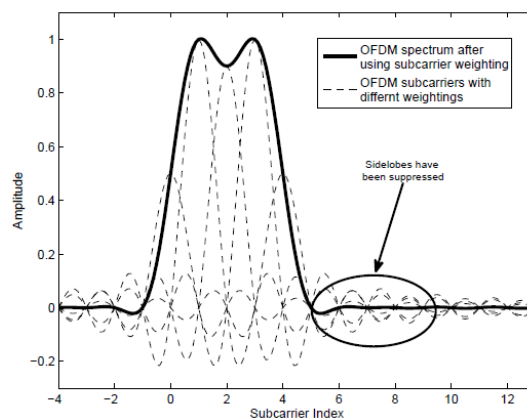

Figure 5. Sub-carrier weighing technique.

3.3 Cancellation Carriers

The cancellation carrier (CC) technique operates by inserting no data information carriers on the left and right hand sides of the OFDM spectrum with optimized weights as shown in Figure 6. In this figure, one CC (dashed line) is inserted on the right side of the OFDM spectrum (solid line) [22].

The amplitude of the CC is calculated to cancel out the sidelobe of the original OFDM signal. However, there is a small loss in bit error rate performance due to transmitting sub-carriers, which are not available for data transmission.

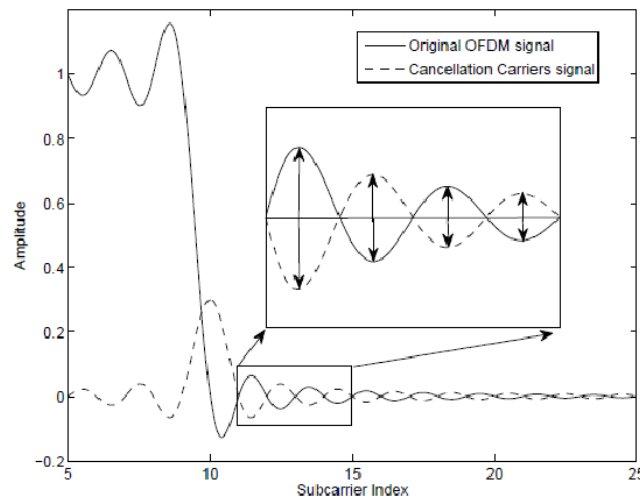

Figure 6. Cancellation carriers technique.

3.4 Raised-Cosine Filter

Raised-cosine a filter is relatively straight forward implementation and has the ability to reduce ISI, thus it is a good candidate to be used for OFDM sidelobe suppression. The ideal raised-cosine filter impulse response that is shown in Figure 7 is defined in [23] as follows:

$$h(t) = \text{sinc}\left(\frac{t}{T}\right) \frac{\cos\left(\frac{\pi\beta t}{T}\right)}{1 - \frac{4\beta^2 t^2}{T^2}} \quad (4)$$

where T is the symbol time. The frequency response of an ideal raised-cosine filter consists of unity gain at low frequencies, a raised-cosine function in the middle frequencies and significant attenuation at high frequencies. The width of the middle frequencies is defined by the roll-off factor β , where $0 < \beta < 1$.

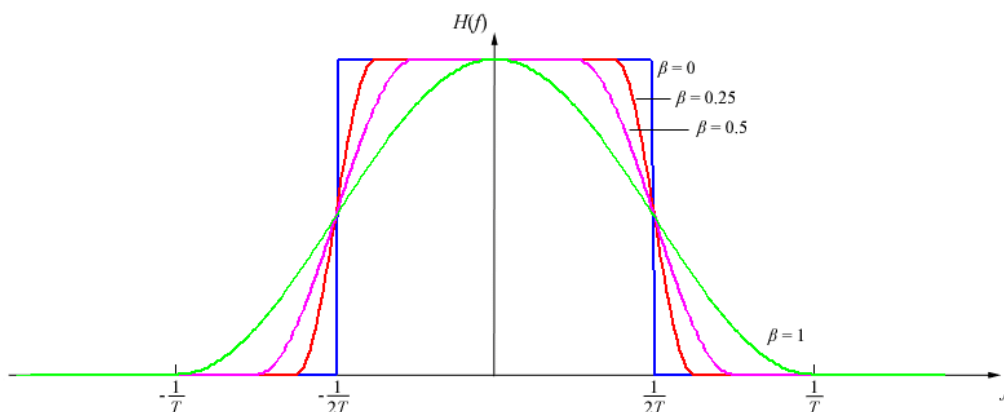

Figure 7. Different roll-off factors for raised-cosine filter.

3.5 Combined Techniques

To achieve better sidelobe suppression, several of the existing techniques can be combined. When digital signal is transmitted, the sidelobe of OFDM signal should be suppressed by 15 dB, which means low enough interference with other transmissions. For some of the techniques mentioned previously, a reduction of about 15 dB can be achieved [24].

By the combination of modulated raised-cosine filter and the cancellation carriers technique, a more reduction in the OOB radiation can be achieved in comparison with using the individual reductions of either technique. [25]. For an ideal raised-cosine filter, the frequency response is symmetric and the center frequency is located at zero. However, the raised-cosine filter needs to be modulated to the location of the OFDM data carrier block. In addition, to ensure that the spectrum is efficiently used and there is no interference with other transmissions by using CCs to reduce the OOB radiation, the sidelobe power of the signal must be suppressed.

4. PROPOSED TECHNIQUE FOR ACI REDUCTION

4.1 Reduction Technique

The proposed technique is based on increasing the resolution in the frequency domain OFDM signal by padding the time domain signal with zeros as illustrated in Figure 8 [26].

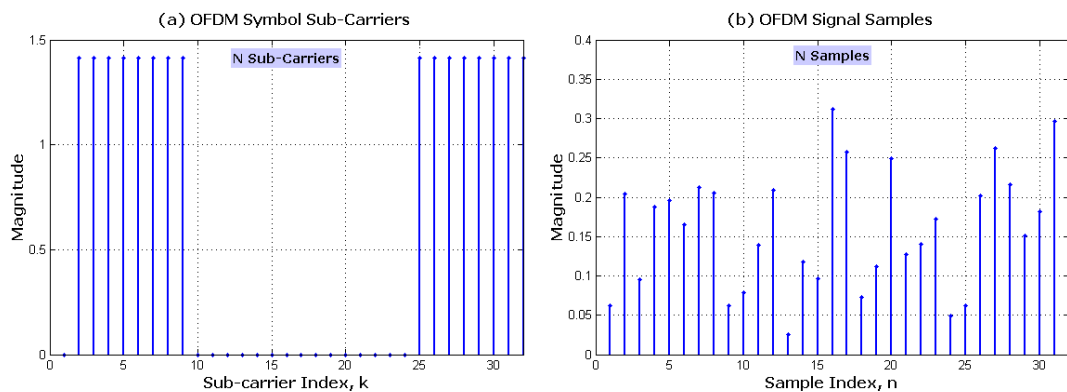

Figure 8. Illustrated OFDM sub-carrier input and output of the IFFT.

The frequency domain signal shows the sidelobes of the OFDM symbol that interfere with the adjacent systems reducing their performance. These sidelobes are selected and padded by zeros in the positions of the desired signal as shown in Figure 9.

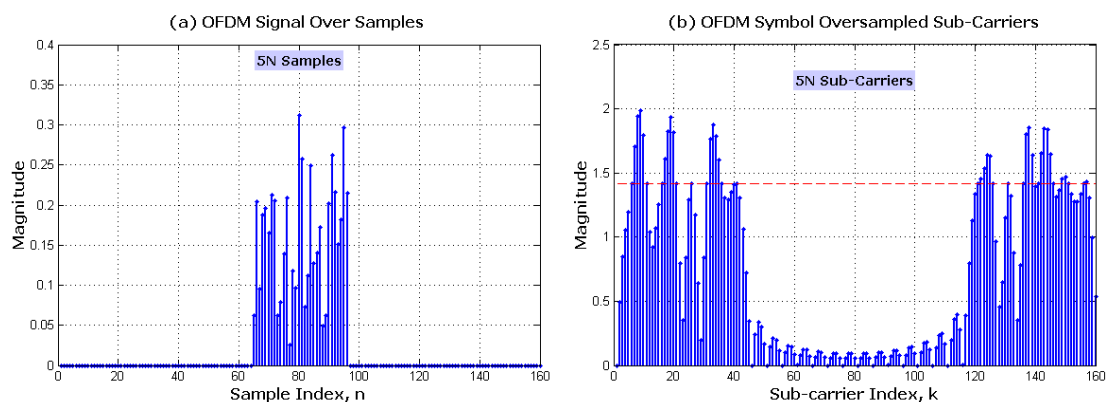

Figure 9. Increasing the resolution in the frequency domain OFDM signal.

At the receiver, these sidelobes do not affect the desired OFDM signal performance, since the FFT process at the receiver only samples the OFDM sub-carriers at the desired sub-carrier frequencies, which are orthogonal and the sampling at the sidelobes returns zero values. These zeros are removed to select only the desired data sub-carriers to be demodulated and detected.

But, when this signal is received by an adjacent system, these sidelobes interfere with the new system data and reduce its performance, resulting in what is called ACI. The sidelobes are selected, zero padded and then inverse Fourier transformed, resulting in a time domain signal that represents the assumed ACI signal as illustrated in Figure 10. The time domain signal in Figure 10b represents the N-samples OFDM signal representing the sidelobes padded to the right and to the left in order to increase the resolution of its frequency domain signal.

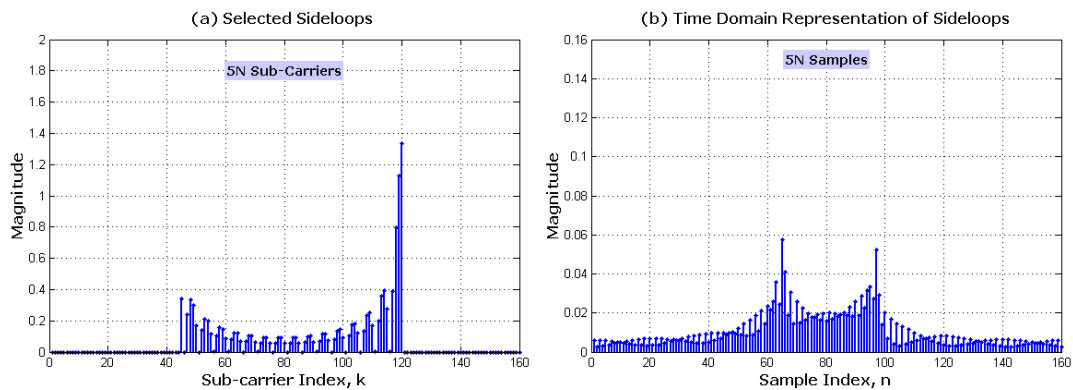

Figure 10. The selected sub-carriers in the sidelobes positions.

To down-sample the frequency domain signal, the padded samples in the time domain must be removed and the resulting samples then Fourier transformed to N-number of pilots at the positions of the desired OFDM sub-carrier frequencies as illustrated in Figure 11.

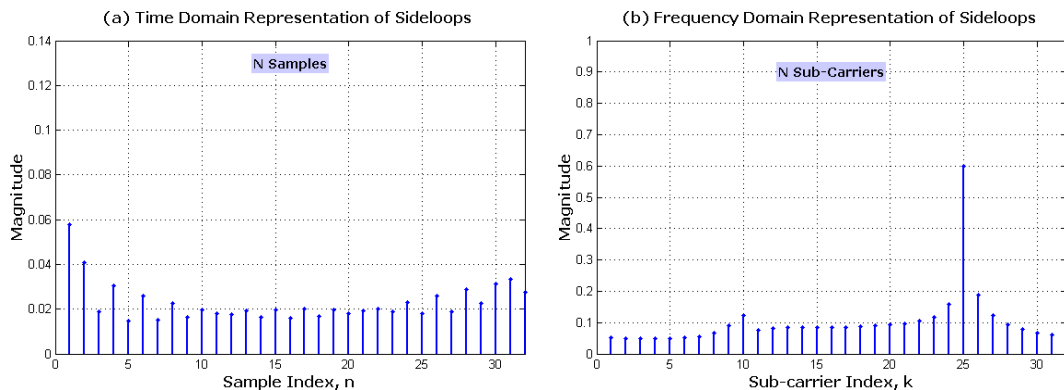

Figure 11. The selected N (number of samples) representation of sidelobes.

In order not to add power at the high frequency sub-carriers that represent the sidelobes, the positions of these sub-carriers are replaced by zeros keeping the needed pilots as a compensated signal to the sidelobes. This is illustrated in Figure 12. These pilots are then extracted from the main data sub-carriers in the desired signal resulting in reduced sidelobes power and ACI.

4.2 Matlab/Simulink Model

In this paper, the simulation model is divided into three parts. The first part is the transmitter (the original signal), then comes the ACI reduction part (ACI signal on the original signal) and finally the receiver part. Data transmission is a binary signal that consists of ones and zeros. The transmitted data are generated by OFDM symbol generator through QPSK mapping, S/P converter, zero padding, IFFT and cyclic prefix, through the transmission channel to the receiver.

Oversampling in OFDM is usually implemented by modulating some sub-carriers at the spectrum margins with zero. In this technique, more resolution in the frequency domain is needed that corresponds to adding zeros to the left and right of the OFDM time domain signal, as in Figure 13. This will increase the time duration of one OFDM symbol without changing the sampling time. By keeping the sampling

time constant, the sampling frequency is kept constant, but the number of frequency components increases due to increasing the FFT size for this process, where each component will have a frequency less than the main sub-carrier frequency of the original OFDM symbol. Looking at the sidelobes of the main OFDM symbol shows zeros (zero padding) at each OFDM subcarrier, whereas after adding zeros at the time domain, frequency components between these zeros appear with some power said to be the ACI affecting the adjacent OFDM signals.

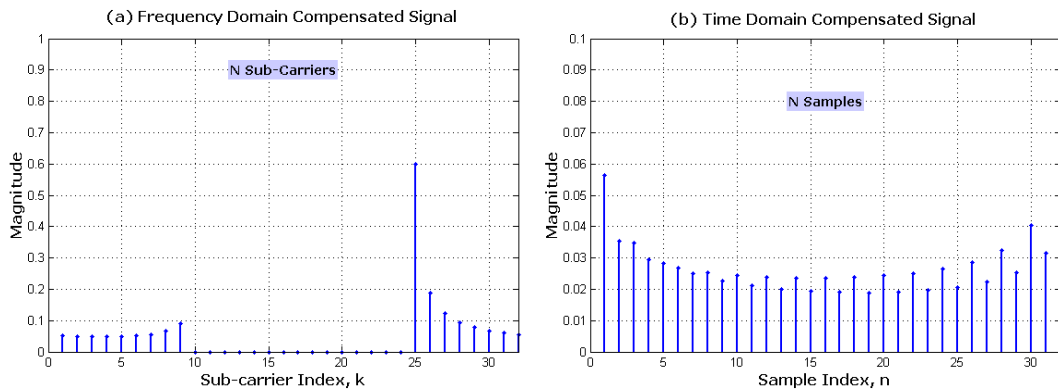

Figure 12. Selecting the sub-carriers that compensate for the ACI.

ACI is a result of the addition process from all the sub-carrier samples in the sidelobes of the OFDM signal. Those sidelobes will interfere with the adjacent OFDM signal. Each OFDM signal has its own sampling frequency reading. So when the desired OFDM signal starts to sample its sub-carriers and because the adjacent OFDM signal is close to it, it will sample the adjacent signal without knowing the difference between the two OFDM signals that would cause an interference or noise. To reduce noise, the power of the OFDM sidelobes has to be reduced.

As shown in Figure 13, the block labelled “Select Sidelobes Zero Padded” selects only these frequencies that represent the ACI and pads the new real data sub-carriers with zeros to reach a new number of IFFT points, as in Figure 14.

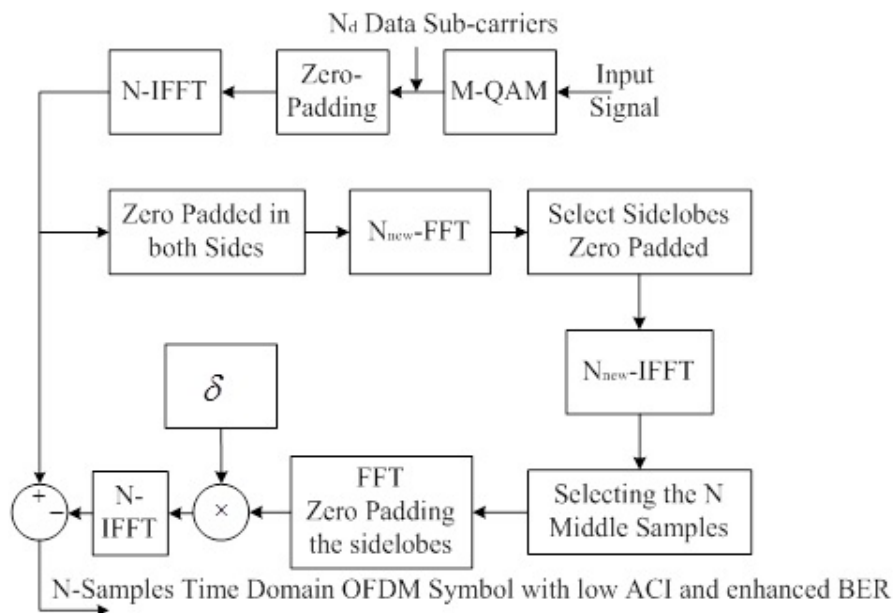

Figure 13. OFDM transmitter using the proposed technique.

The zero padded frequency domain signal is converted into the time domain using N_{new} -IFFT process, where N_{new} is the N original number of OFDM samples with the new zeros added as samples to the time domain signal.

The resulting N -number of samples in the middle of the output of the N_{new} -IFFT process is selected, which is assumed to be the power added to the original signal producing more power in the sidelobes. These sub-carriers are then translated to the frequency domain by N-FFT process, which results in some power components at the positions of the original N_d data sub-carriers, whereas the other components are neglected because we do not want to add more power to the zeros of the original signal that increases the ACI. The resulting frequency components are then multiplied by δ -factor to compromise for the BER performance of the system, since these components represent noise to the original signal.

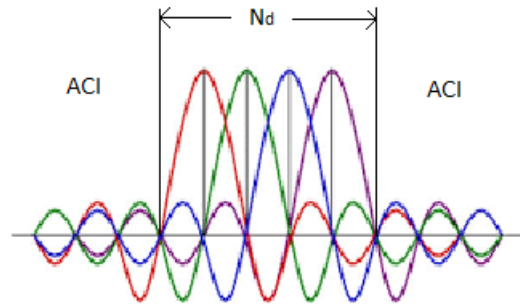

Figure 14. OFDM sub-carriers three-part division.

The resulting optimized frequency components are then transformed to the time domain by N-IFFT process and subtracted from the original OFDM signal, producing an OFDM signal with low power in the sidelobes; i.e., low ACI.

4.3 OFDM System Parameters

The proposed ACI reduction technique discussed in the previous section is assessed using a Matlab/Simulink simulation. The OFDM system parameters are based on the next generation of mobile communication systems and their values that are used for the performance assessment under the effect of AWGN channel are presented in Table 1 [10]-[11].

The cyclic prefix length is proposed to be greater than or equal to the maximum delay spread in urban channels proposed by the CODIT channel model [27].

Table 1. OFDM system parameters.

Description	Value
Modulation type	$M = 4$ (QPSK)
Cyclic prefix	$T_g \geq \tau_{\text{max}} = 4 \mu\text{s}$
Bandwidth	$BW = 20 \text{ MHz}$
OFDM symbol useful time duration	$T = 4 \times T_g = 16 \mu\text{s}$
Sub-carrier frequency	$f_{sc} = \frac{1}{T} = 62.5 \text{ kHz}$
Number of data sub-carriers	$N_d = \frac{BW}{f_{sc}} = 320$
FFT size	$N = 1024$

4.4 Simulation Steps

MATLAB/Simulink is a block diagram environment for multi-domain simulation and model-based design. Simulink provides a graphical editor, block libraries and solvers for modeling and simulating dynamic systems.

Through the study, the main reason of the interference is the sum of sub-carrier samples in the sidelobes

of OFDM symbol (out-of-band radiation). Reducing those radiations on the adjacent channels as much as possible with preserving the original data signal in the desired frequency is the main idea of the thesis.

Figure 15 shows the general block of the first step for the simulation; getting the information signal from the Bernoulli binary generator, then processing it through the OFDM transmitter system, which will be explained in the next section, adding ACI-1 and ACI-2 with the output of OFDM transmitter system, then processing the result through AWGN generator to the receiver to calculate the BER to know the amount of error.

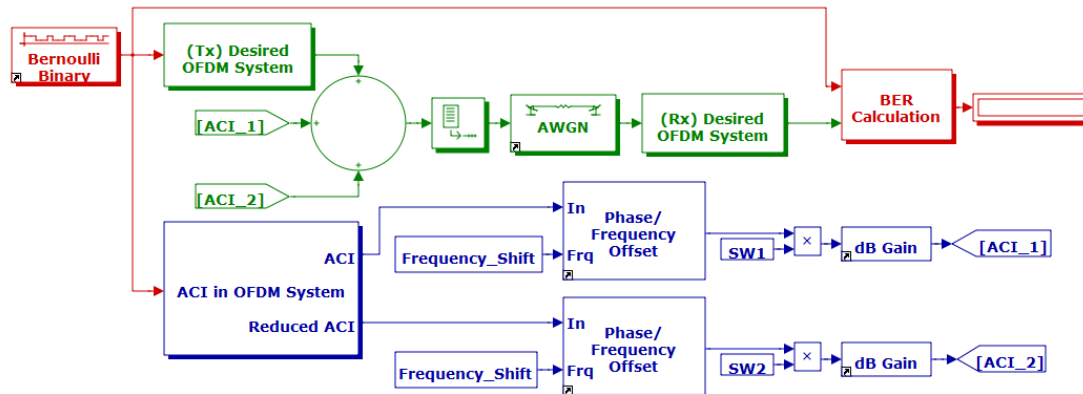

Figure 15. General block diagram of simulation.

ACI-1 represents the interference from the adjacent channel that affects the desired signal and ACI-2 represents the interference from the adjacent channel that affects the desired signal but after using the reduction technique. The frequency shift block is used to shift the frequency of the adjacent OFDM interference signal that affects the desired signal. In this thesis, the frequency would be shifted to the left by three values -20.1 MHz, -20.05 MHz and -20 MHz. ACI-1 and ACI-2 can be controlled by the switches SW1 and SW2 by multiplying the switches by 1 to open them and 0 to close them.

The power of the adjacent OFDM interference signal could be higher or lower than or equal to the power of the desired signal like -6 dB, -3 dB or 0 dB, which can be controlled by the gain of the signal.

Figure 16 shows the transmitter of the desired OFDM signal without ACI effect. The data transmitted is a binary signal which consists of ones and zeros.

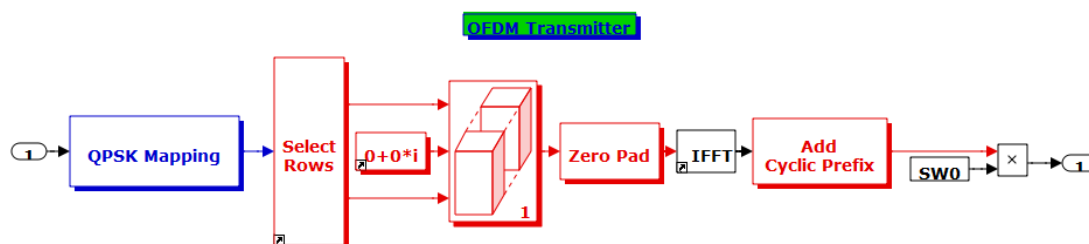

Figure 16. Transmitter of the desired signal.

Data is generated by OFDM symbol generator through QPSK mapping, S/P converter, zero padding, IFFT, cyclic prefix and up converting through the transmission channel. Figure 15 represents the ACI reduction technique applied on the adjacent OFDM signal that affects the desired signal. The difference between the desired signal and the output of this transmitter is the frequency shift, which has been explained above. Figure 17 has two outputs; the first one is the same as the desired signal, but shifted in frequency, while the second output is the same as the desired signal, but with ACI reduction technique.

ACI reduction block diagram represents the technique of reduction, which has been previously mentioned. After adding the zeros to the time domain OFDM signal samples, the OFDM symbol sub-carriers will be increased in the sampling points. The purpose of increasing the sampling points is to see the sidelobe power that causes an interference to the adjacent systems.

To study the interfering sidelobes, these have to be selected with removing the OFDM data sub-carriers in the medial, then adding zeros to the left and the right in order to compensate for the data having been removed.

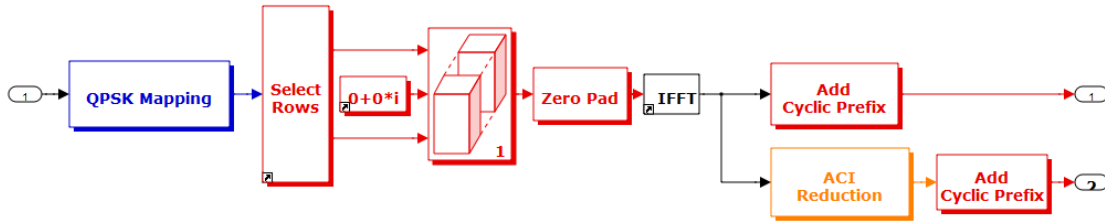

Figure 17. Transmitter of the desired signal with ACI reduction.

After processing the result through IFFT, the output will be the ACI signal presented in time domain. Choosing the N samples for OFDM signal, then down-sampling the signal by removing the added zeros in time domain from the beginning, then processing it through the FFT will lead to obtain a representation of the N number of sub-carriers in frequency domain for the sidelobe power.

4.5 Simulation Result

4.5.1 ACI Mitigation for QPSK-OFDM Signal at Zero dB Attenuation Factor

A comparison between BER and SNR values will be presented. All the figures below show the performance of QPSK-OFDM signal with zero attenuation factor ($\delta = 0$), but with different frequency shift and ACI gain values. When the attenuation factor is equal to zero dB, the attenuation will be unity, which means that all the power of the generated signal for ACI reduction is subtracted from the power of the data sub-carrier on the sidelobes of the original OFDM signal.

Figure 18 shows the BER performance when the gain of the adjacent interference signal is -6 dB below the original signal and the attenuation factor is 0 dB. As the SNR increases, the BER decreases. If the adjacent OFDM interference signal frequency is -20.1 MHz away from the desired one, and at $SNR = 8\text{ dB}$, the BER is about 5×10^{-5} for both of the adjacent interference signals with and without ACI reduction. The BER for the desired OFDM signal at 8 dB is about 3×10^{-6} .

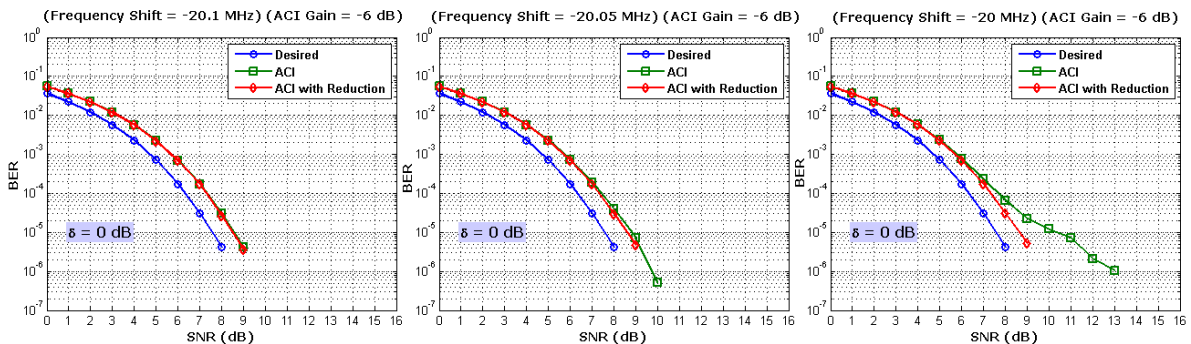

Figure 18. BER vs SNR QPSK-OFDM signal at -6 dB ACI gain with 0 dB attenuation factor.

For closer adjacent channel interference (-20.05 to -20 MHz), the BER performance decreases due to more interference power added to the desired signal. In Figure 18c, the BER increased to about 8×10^{-4} for the ACI without reduction while no change occurred by using the reduction technique.

These results are due to the -6 dB difference in the signal power between the adjacent and the desired signals as shown in Figure 19, which shows the performance of PSD using 0 dB weighing factor with different frequency shifts. The PSD for the ACI signal at the center frequency is almost -39 dBm and for the ACI signal after reduction is about -48 dBm, which is about 9 dB reduction. In fact, this is not the real difference since the reduction in power is measured as the average signal power to the average interference power, which is analyzed in Section 4.5.3 below.

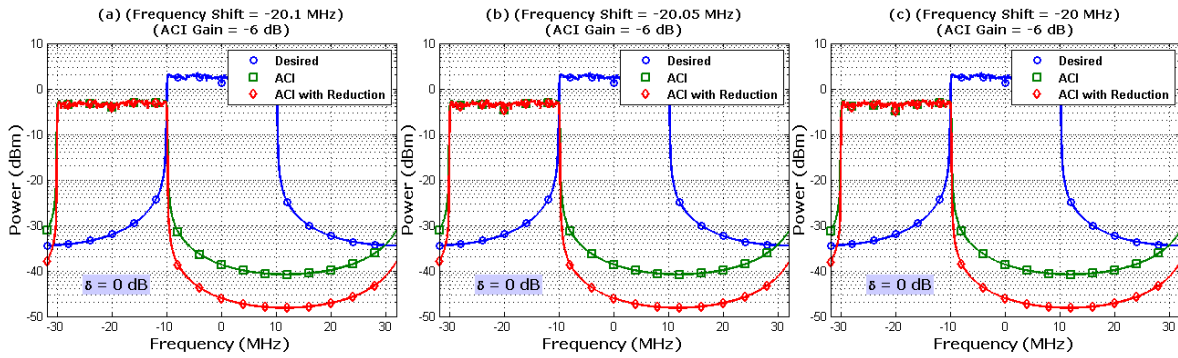

Figure 19. PSD of QPSK-OFDM signal at -6 dB ACI gain with 0 dB attenuation factor.

Figure 20 represents a clarification for Figure 19 for the PSD at different frequency shift values. Table 2 shows the power values for the adjacent OFDM interference signal that affects the desired OFDM signal. From the table, the closer the adjacent OFDM signal the higher the power that affects the desired OFDM signal, which means more ACI on the desired signal.

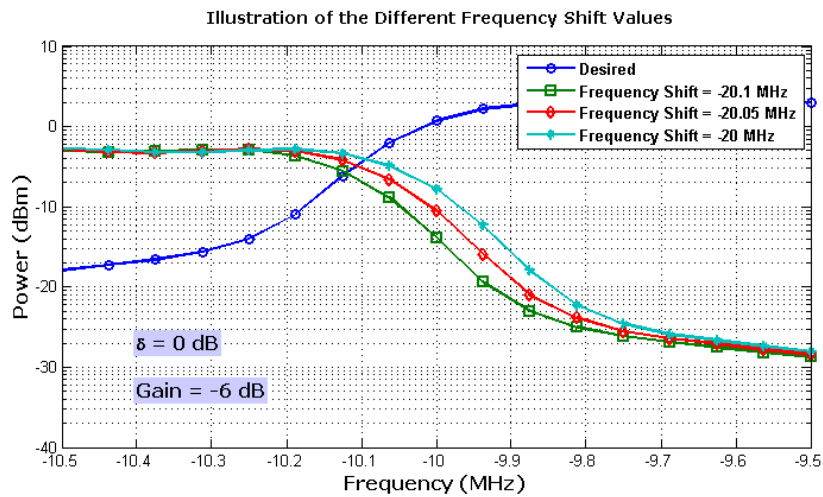

Figure 20. Illustration for PSD QPSK-OFDM signal at -6 dB ACI gain with 0 dB attenuation factor.

Table 2. PSD different values at -6 dB ACI gain with 0 dB attenuation factor.

Frequency (MHz)	Frequency shift (MHz)	PSD (dBm)
-10	-20.1	-16
-10	-20.05	-11
-10	-20	-8

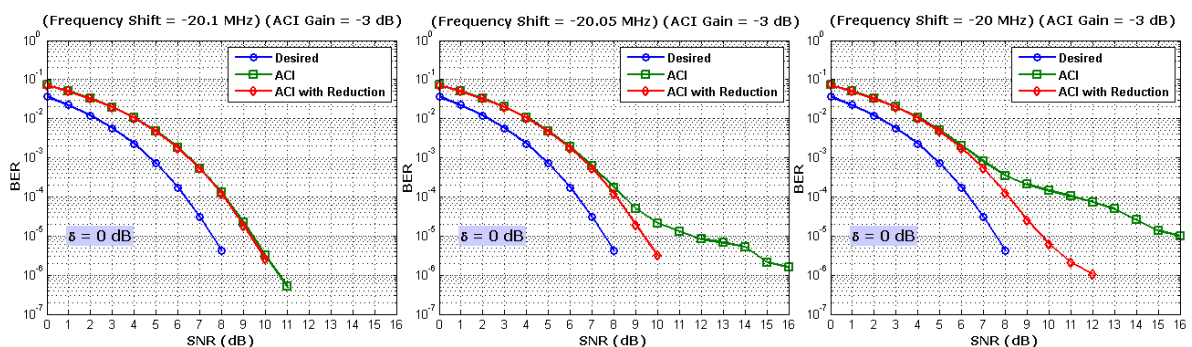

Figure 21. BER vs SNR QPSK-OFDM signal at -3 dB ACI gain with 0 dB attenuation factor.

If the adjacent channel has a higher gain, the effect of the interference on the desired signal would be higher.

Figure 21 shows the BER performance for -3 dB difference between the adjacent and the desired signals for different frequency separations. This shows an increase in the BER, especially when the adjacent signal is at -20 MHz to the desired one.

Figure 22 shows the performance of PSD at -3 dB difference, which shows that the sidelobe power is now closer to the desired OFDM data sub-carriers, resulting in an increase in the BER.

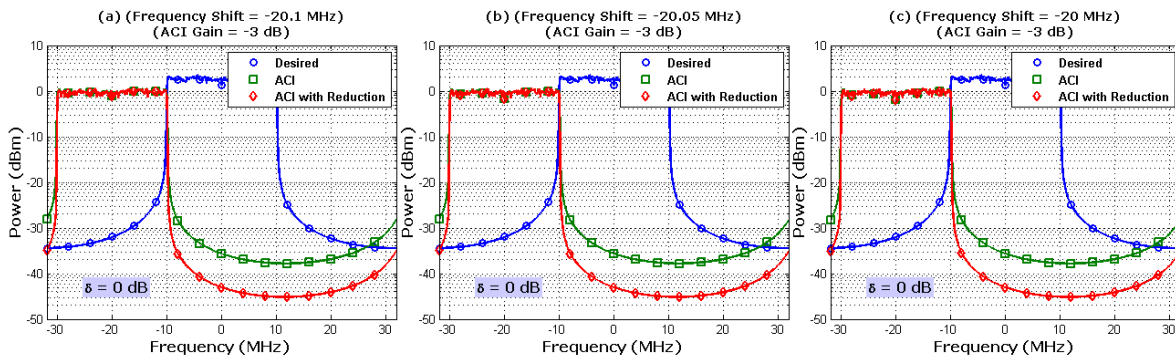

Figure 22. PSD of QPSK-OFDM signal at -3 dB ACI gain with 0 dB attenuation factor.

Figure 23 represents a clarification for Figure 22 for the PSD at different frequency shift values. Table 3 shows the power values for the adjacent OFDM interference signal that affects the desired OFDM signal. From the table, the closer the adjacent OFDM signal, the higher the power that affects the desired OFDM signal, which means more ACI on the desired signal.

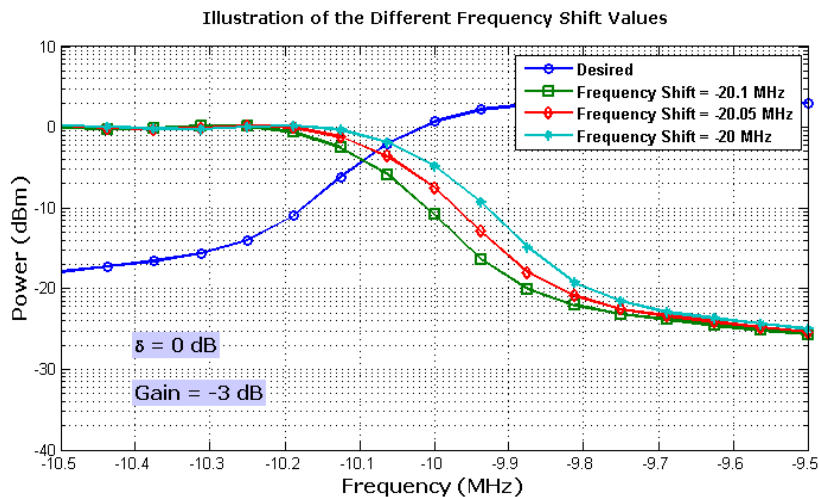

Figure 23. Illustration for PSD QPSK-OFDM signal at -3 dB ACI gain with 0 dB attenuation factor.

Table 3. PSD different values at -3 dB ACI gain with 0 dB attenuation factor.

Frequency (MHz)	Frequency shift (MHz)	PSD (dBm)
-10	-20.1	-12
-10	-20.05	-8
-10	-20	-7

Increasing the gain power for the adjacent signal will increase the interference with the desired signal. From Figure 24, the BER amount is increasing, because the value of the gain power is increased, but the best ACI reduction amount is when the frequency shift of the adjacent signal is at -20 MHz; a reduction from 10^{-3} to 10^{-4} at 9 dB SNR. A reduction of 10 dBm at 10 MHz from -35 dBm to -45 dBm

on the sidelobe power is obtained after using the ACI reduction technique as shown in Figure 25.

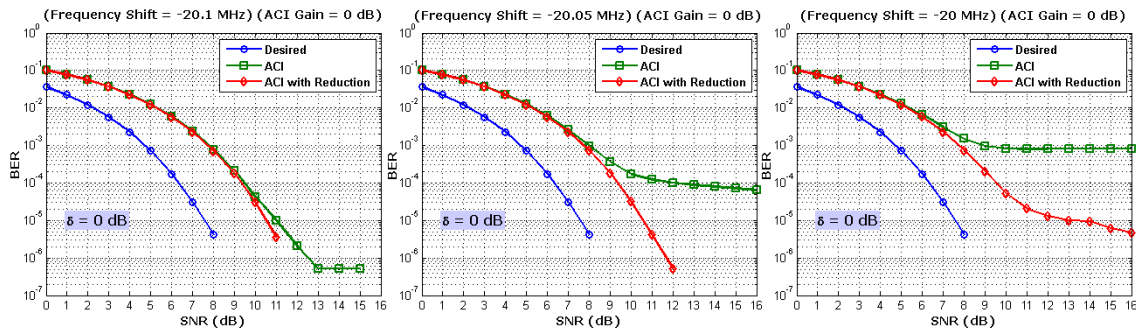

Figure 24. BER vs SNR for QPSK-OFDM signal at 0 dB ACI gain with 0 dB attenuation factor.

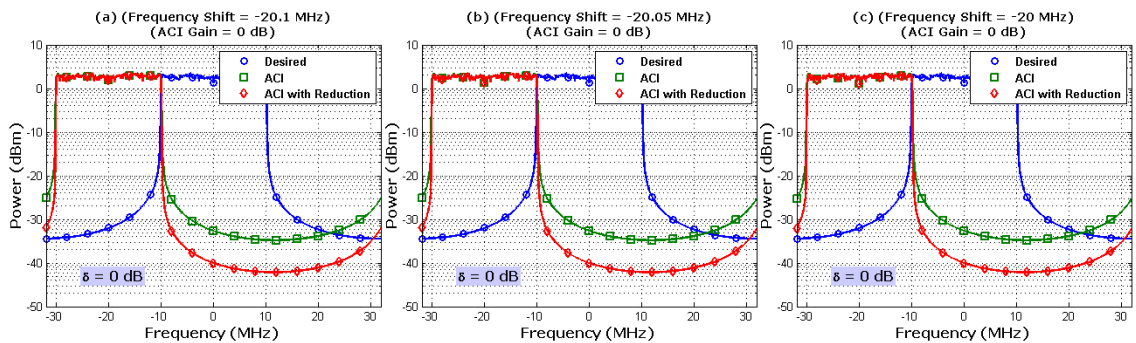

Figure 25. PSD of QPSK-OFDM signal at 0 dB ACI gain with 0 dB attenuation factor.

Figure 26 represents a clarification for Figure 25 for the PSD at different frequency shift values. Table 4 shows the power values for the adjacent OFDM interference signal that affects the desired OFDM signal.

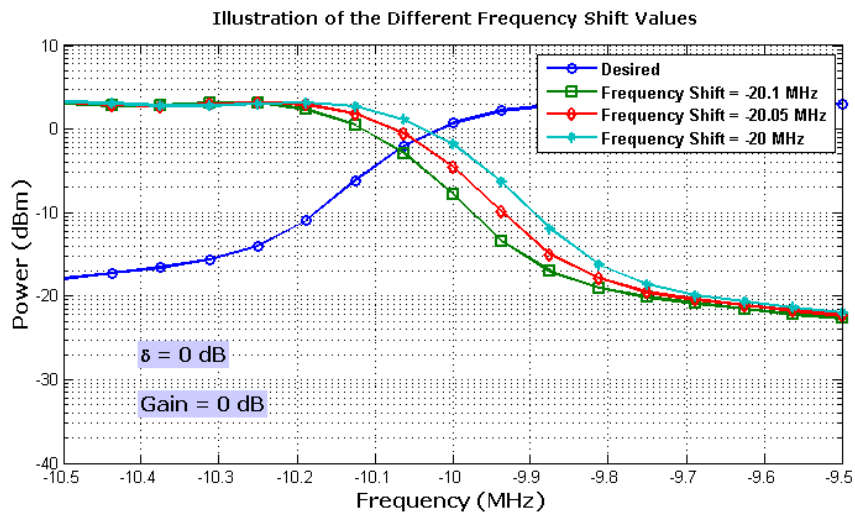

Figure 26. Illustration for PSD QPSK-OFDM signal at 0 dB ACI gain with 0 dB attenuation factor.

Table 4. PSD different values at 0 dB ACI gain with 0 dB attenuation factor.

Frequency (MHz)	Frequency shift (MHz)	PSD (dBm)
-10	-20.1	-8
-10	-20.05	-6
-10	-20	-4

From the table above, the closer the adjacent OFDM signal, the higher the power that affects the desired OFDM signal, which means more ACI on the desired signal. Figure 27 shows the BER and SNR when the gain of the adjacent interference signal is 3 dB and the attenuation factor on the sidelobes is 0 dB. When the adjacent OFDM interference signal is received by a gain power higher than the power of the desired signal, the interference will increase. Because the BER values are much higher than the previous results, the ACI reduction is not as strong as the ACI reduction resulting at 0 dB ACI gain.

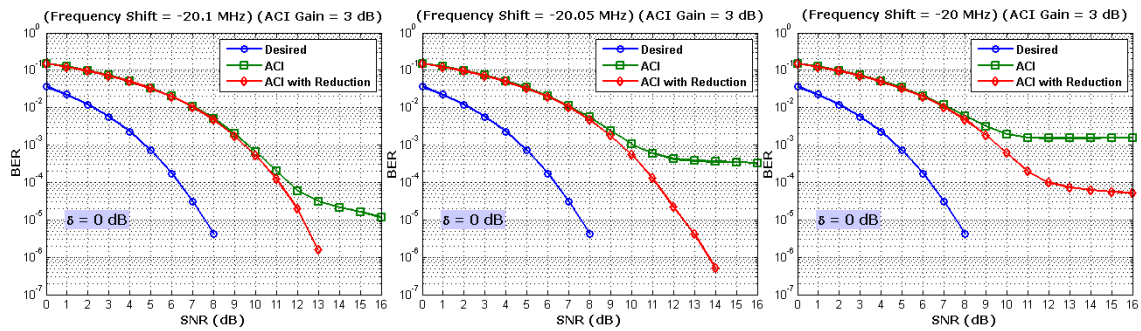

Figure 27. BER vs SNR for QPSK-OFDM signal at 3 dB ACI gain with 0 dB attenuation factor.

Increasing the gain power of the adjacent signal will increase the interference on the desired signal as shown in Figure 28. The PSD performance is reduced by 9 dB from -30 dBm to -39 dBm at the center frequency. This is also not the real difference, since the reduction in power is measured as the average signal power to the average interference power, which will be analyzed in Section 4.5.3 below as mentioned before.

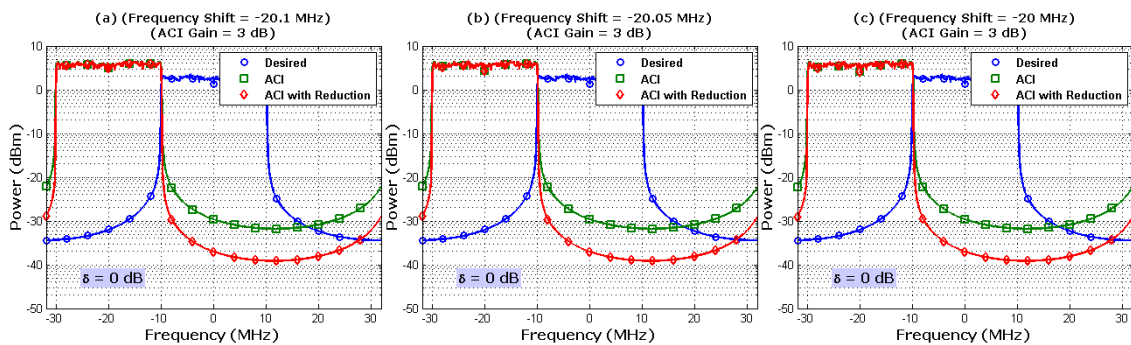

Figure 28. PSD of QPSK-OFDM signal at 3 dB ACI gain with 0 dB attenuation factor.

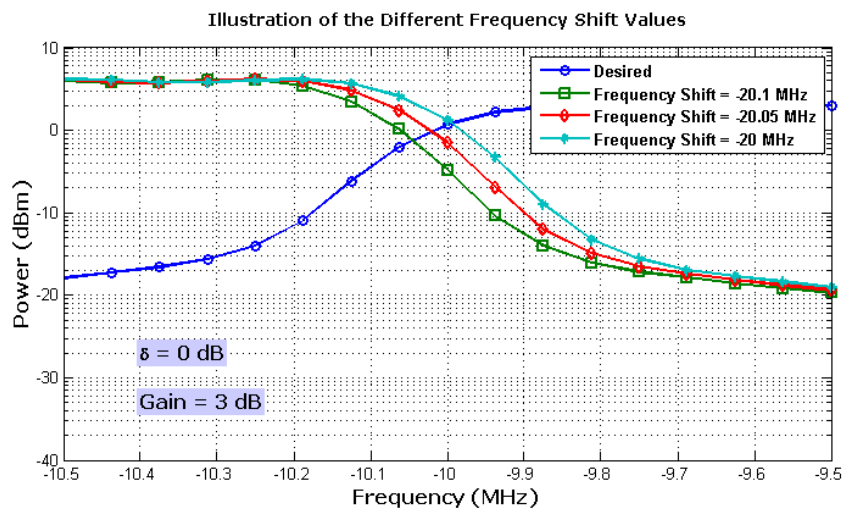

Figure 29. Illustration for PSD QPSK-OFDM signal at 3 dB ACI gain with 0 dB attenuation factor.

A clarification for Figure 28 is shown in Figure 29, where the performance of the PSD QPSK-OFDM signal at different frequency shift values is presented. Table 5 shows the power values for the adjacent OFDM interference signal that affects the desired OFDM signal.

Table 5. PSD different values at 3 dB ACI gain with 0 dB attenuation factor.

Frequency (MHz)	Frequency shift (MHz)	PSD (dBm)
-10	-20.1	-7
-10	-20.05	-3
-10	-20	1

4.5.2 ACI Mitigation for QPSK-OFDM Signal at -3 dB Attenuation Factor

All the figures below show the performance of a 20 MHz bandwidth QPSK-OFDM signal with -3 dB attenuation factor, but with different frequency shift and ACI gain values. When the attenuation factor is equal to -3 dB, the power of the generated oversampling signal for ACI reduction method is reduced to the half and subtracted from the power of the data sub-carrier on the sidelobes of the original OFDM signal, which means less sidelobe power reduction than by using zero attenuation factor. A comparison between BER vs SNR and PSD with different frequency shift and ACI gain values will be presented in the figures below.

Figure 30 shows the BER and SNR when the adjacent signal gain power is reduced to -6 dB with different frequency shifts values. When the SNR is 9dB, the best BER reduction is at -20 MHz.

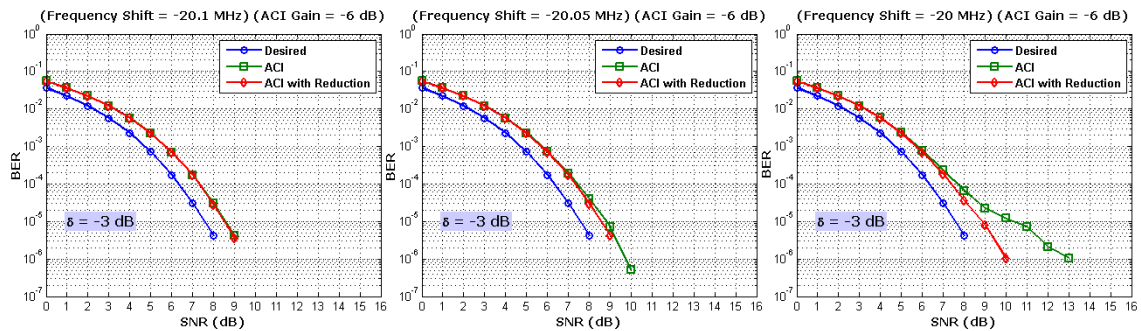

Figure 30. BER vs SNR for QPSK-OFDM signal at -6 dB ACI gain with -3 dB attenuation factor.

Figure 31 represents the PSD values. The reduction in the sidelobes is less than the previous results, because the gain power is minimum and the attenuation factor on those sidelobes is less than one. From the figure above, the PSD for the ACI signal at the center frequency is about -40 dBm and for the ACI signal after reduction is about -47 dBm, which is about 7 dB reduction. In fact, this is not the real difference, since the reduction in power is measured as the average signal power to the average interference power, which is analyzed in Section 4.5.3 below.

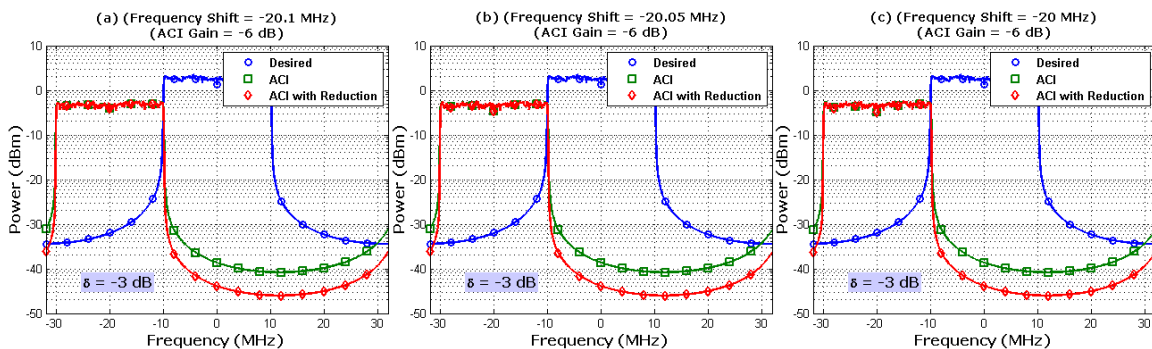

Figure 31. PSD of QPSK-OFDM signal at -6 dB ACI gain with -3 dB aAttenuation factor.

After increasing the gain power of the adjacent signal, the BER vs SNR performance is also increased.

Figure 32 shows that the best ACI reduction is at -20 MHz, as the BER is reduced from 10^{-3} to less than 10^{-4} at 9 dB SNR.

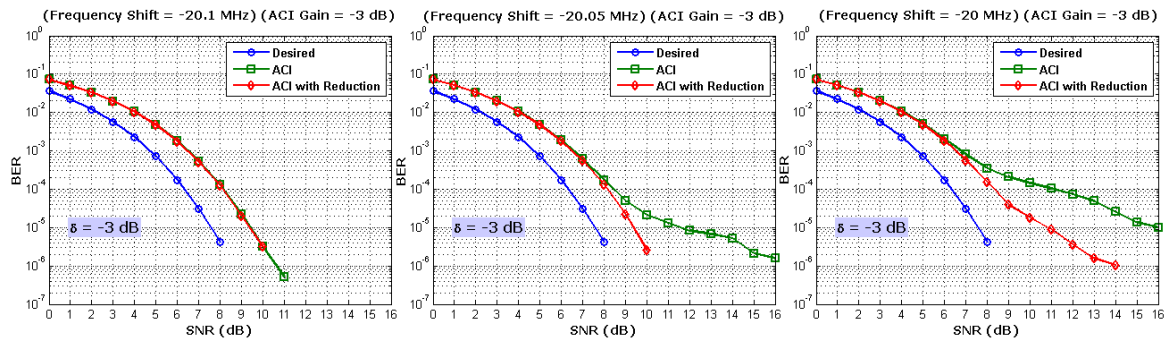

Figure 32. BER vs SNR for QPSK-OFDM signal at -3 dB ACI gain with -3 dB attenuation factor.

Figure 33 represents the PSD performance after increasing the adjacent signal gain power. It can be seen that the interference is increased on the desired signal, but a reduction of 7 dB on the power of the sidelobes is achieved after using the ACI reduction technique.

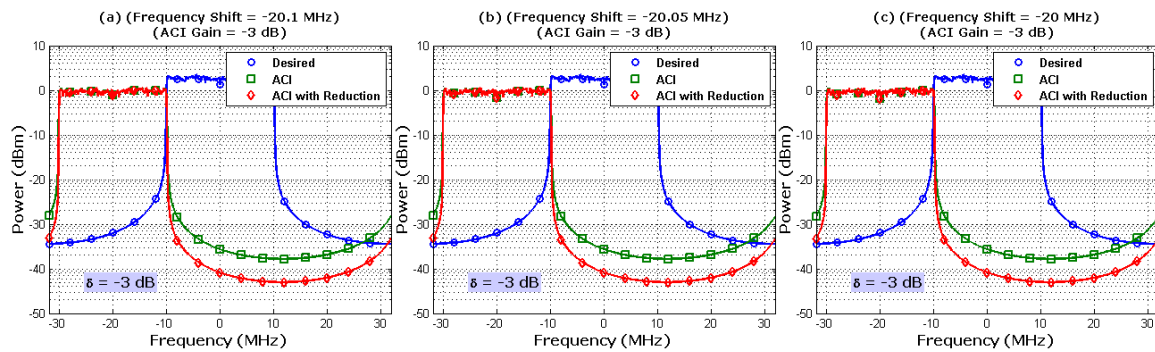

Figure 33. PSD of QPSK-OFDM signal at -3 dB ACI gain with -3 dB attenuation factor.

The BER gets higher as the adjacent signal power is increased. Figure 34 shows that the closer the adjacent signal to the desired signal, the better the ACI reduction.

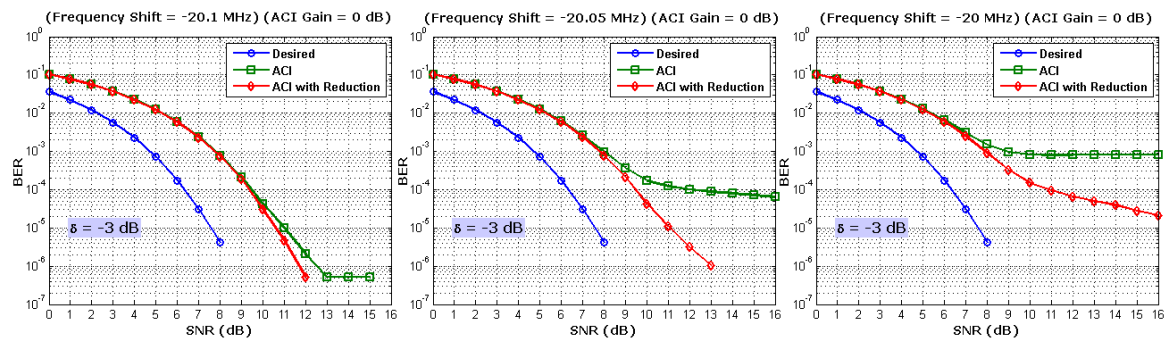

Figure 34. BER vs SNR for QPSK-OFDM signal at 0 dB ACI gain with -3 dB attenuation factor.

The effect of the sidelobe power from the adjacent signal is shown in Figure 35. As the PSD is increased because of the increment of ACI gain power, a reduction can be achieved by using half power sidelobe reduction technique.

The figures below represent half sidelobe power reduction with amplified adjacent gain power. The BER performance is getting higher than the previous results, because the gain is higher and so the amount of interference is higher. But, after using the ACI reduction technique, the BER is enhanced at a minimum value as shown in Figure 36.

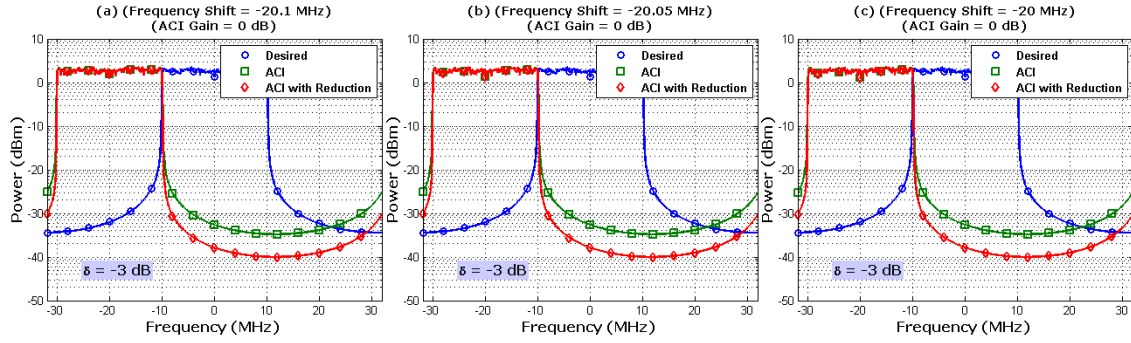

Figure 35. PSD of QPSK-OFDM signal at 0 dB ACI gain with -3 dB attenuation factor.

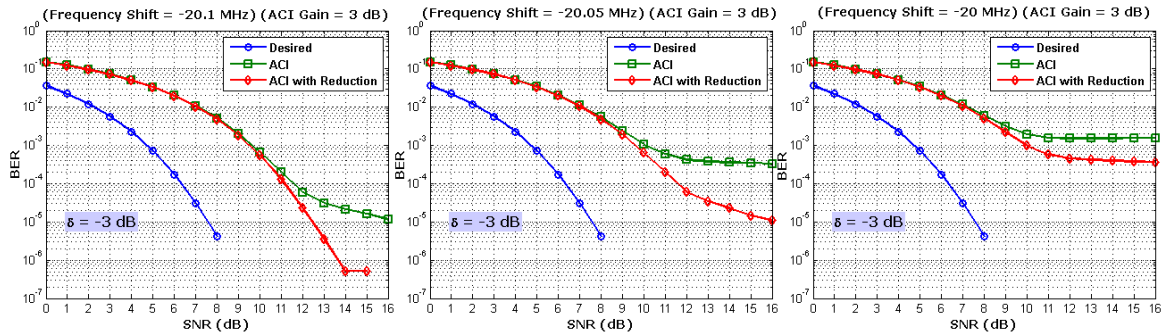

Figure 36. BER vs SNR for QPSK-OFDM signal at 3 dB ACI gain with -3 dB attenuation factor.

The interference from the adjacent sidelobes on the desired signal is very obvious. In Figure 37, at -10 MHz, the adjacent signal with ACI has a higher power than the desired signal at the same frequency, but after using ACI reduction technique, the adjacent power is reduced by 6 dB, which reduces the effect of interference and increases the system performance.

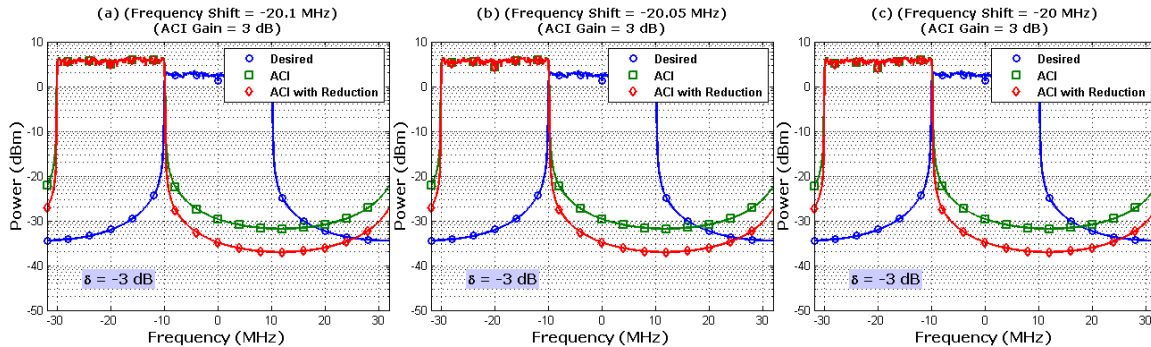

Figure 37. PSD of QPSK-OFDM signal at 3 dB ACI gain with -3 dB attenuation factor.

4.5.3 Signal to Interference Ratio (SIR) Analysis

The SIR is a comparison tool between the desired signal's average power to that of the interference signal, which is given as follows:

$$SIR = \frac{P_{Desired}}{P_{ACI}} \quad (5)$$

$$SIR_{dB} \downarrow = P_{Desired}^{dB} - P_{ACI}^{dB} \uparrow$$

Figure 38 illustrates the different SIR values between the desired OFDM signal's power and that of the ACI signal's power with and without applying the reduction technique. This illustration is done for the three different ACI applied frequencies and with different values of reduction factor δ .

Figure 38a shows that as the ACI power increases, the SIR decreases as given in Equation (5).

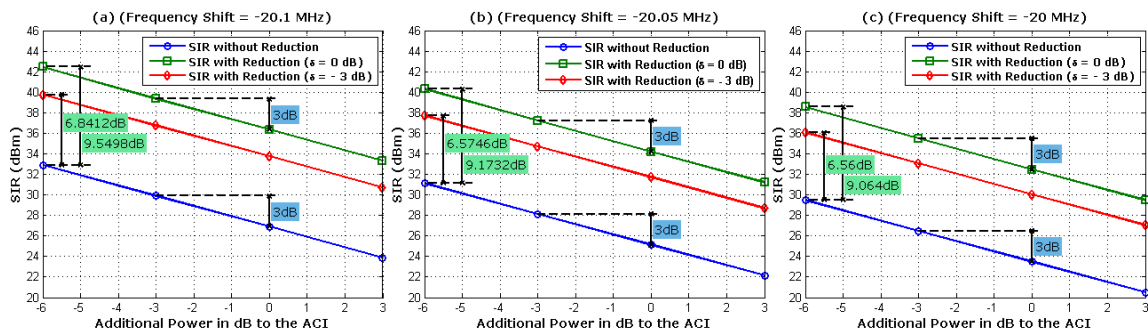

Figure 38. SIR comparison between the desired OFDM signal and the ACI signals.

In our simulation, four steps of increasing the ACI power by 3 dB each time are made from -6 dB to 3 dB and at each time the SIR decreases by 3 dB as shown in the figure.

The improvement in SIR is illustrated and found to be about 9 dB between the desired signal and the ACI signal after reducing the power at the sidelobes with a reduction factor of $\delta = 0$ dB, whereas for the ACI signal, with a reduction factor of $\delta = -3$ dB, the SIR is lower than before with a value of about 6.5 dB.

This result is due to the power of the added signal to the desired signal as a reduction technique. For $\delta = 0$ dB, no change occurs on the added (noise) signal, which results in more reduction on the sidelobes, therefore causing more SIR. But, for $\delta = -3$ dB, the power of the added signal is reduced to the half, which results in less reduction in the power of the sidelobes, leading to lower the SIR in comparison with the case before. In both cases, the SIR is improved.

Figure 38b and Figure 38c show the same analysis, but with one difference, which is that the value of the SIR is lowered. The reason behind this is the amount of power introduced by the ACI signal at its center frequency, becoming closer to the desired signal.

5. CONCLUSIONS

This work addresses the problem of ACI between the OFDM symbols. Through the study, the main reason of the interference is the sum of sub-carrier samples in the sidelobes of the OFDM symbol (out-of-band radiation). The purpose of this work is to reduce this radiation on the adjacent channels as much as possible, while preserving the original data signal in the desired frequency.

The operation that had been used in this paper is based on adding zero pilots in the time domain of the OFDM symbol, resulting in more resolution in the frequency domain, which would help reduce the out-of-band radiation.

The system speed is related to the sampling frequency of the FFT process, which is $f_s = 1/t_s = Nf_{sc}$. In this paper, as given in Table 1, the sampling frequency is given by $f_s = 1024 \times 62.5 \text{ kHz} = 64 \text{ MHz}$. By adding zeros to the time domain signal, nothing changes to the sampling frequency, since the zeros have the same sampling time. The change will be in the sub-carrier frequency, since the OFDM useful time duration increased and that led to decrease the sub-carrier frequency. The main idea about this technique is to increase the resolution in the frequency domain. The main effect is on the processing time that increased by increasing the size of the FFT process in this stage. The result after processing the frequency domain signal will be the opposite of the original form, but without data sub-carriers. That means only the addition of sub-carrier samples in the sidelobes, but with a negative power. Subtracting the new signal from the original signal will produce an OFDM signal with less sidelobe power to reduce ACI effect between the OFDM symbols.

From the results, the three main variables that affect the ACI reduction technique are: the attenuation factor, the ACI gain and the frequency shift. The attenuation factor controls the amount of the reduction on the sub-carrier sidelobe power. In the paper, two values are used for the attenuation factor: 0 dB, which means that all the power of the generated signal for ACI reduction method is subtracted from the power of the data sub-carrier on the sidelobes of the original OFDM signal. In case of the other value of

the attenuation factor is -3 dB, the power of the generated signal is reduced to the half and then subtracted from the power of the data sub-carrier on the sidelobes of the original OFDM signal, leading to less sidelobe power reduction than using zero attenuation factor. The second variable is the ACI gain; the adjacent signal gain power is very effective on how much the interference on the desired OFDM signal is. Four values for ACI gain (-6, -3, 0, 3) dB were taken to recognize the difference. The higher the gain power of the adjacent signal, the more interference on the sidelobe of the desired signal. The last variable mentioned in this work is the frequency shift. The closer the frequency of the adjacent signal, the higher the interference that affects the desired signal.

This reduction technique introduces a reduction of 9 dB SIR when using an attenuation factor of $\delta = 0$ dB, where this value reduces as the center frequency of the ACI approaches the desired signal due to the increase of the ACI power near the desired one. For $\delta = -3$ dB, a reduction of about 6 dB is achieved.

REFERENCES

- [1] V. K. Garg and J. E. Wilkes, *Wireless and Personal Communications Systems*, Upper Saddle River, NJ: Prentice - Hall PTR, 1996.
- [2] A. Goldsmith, *Wireless Communication*, New York: Cambridge University Press, 2005.
- [3] G. Jiann-Ching, A. Khayrallah and G. E. Bottomley, "Adjacent Channel Interference Rejection for Land Mobile Radio Systems," in the 48th IEEE Vehicular Technology Conference (VTC 98), pp. 1715-1719, vol. 3, 1998.
- [4] P. Dely, M. C. Castro and A. J. Kassler, "Impact of Adjacent Channel Interference on Performance of Multi-Radio Multi-Channel Mesh Networks," *European Collaborative Innovation Centres for Broadband Media Services*, 2014.
- [5] H. Holma and A. Toskala, *1970-WCDMA for UMTS: Radio Access for Third Generation Mobile Communications*, 2nd Ed., Chichester: Wiley, 2002.
- [6] W. C. Y. Lee, *Mobile Communications Design Fundamentals*, 2nd Ed., New York; Chichester: Wiley, 1993.
- [7] W. C. Y. Lee, *Mobile Communications Engineering: Theory and Applications*, 2nd Ed., New York; London: McGraw-Hill, 1998.
- [8] J. Kimery, "802.11ac Adjacent Channel Interference (ACI)," 14-April-2016, [Online], Available: <https://ytd2525.wordpress.com/category/signaling/>.
- [9] L. Hanzo, M. Münster, B. J. Choi and T. Keller, *OFDM and MC-CDMA for Broadband Multi-User Communications, WLANs and Broadcasting*, John Wiley & Sons, Ltd., July 2003.
- [10] R. V. Nee and R. Prasad, *OFDM for Wireless Multimedia Communications*, Boston; London: Artech House Publisher, 2000.
- [11] R. Prasad, *OFDM for Wireless Communications Systems: Artech House, Universal Personal Communications Series*, 2004.
- [12] K. G. Samarah, *High Bit Rate Air Interface for Next Generation Mobile Communication Systems*, Ph.D. Dissertation, School of Engineering, Design and Technology, University of Bradford, Bradford, 2007.
- [13] I. A. Glover and P. M. Grant, *Digital Communications*, London: Prentice-Hall, 1998.
- [14] D. J. Defatta, J. G. Lucas and W. S. Hodgkiss, *Digital Signal Processing: A System Design Approach*, Chichester: Wiley, 1988.
- [15] J. G. Proakis and D. G. Manolakis, *Digital Signal Processing: Principles, Algorithms and Applications*, 2nd Ed., New York; Toronto; New York: Macmillan; Maxwell Macmillan Canada; Maxwell Macmillan International, 1992.
- [16] S. Pagadarai, *Sidelobe Suppression for OFDM-Based Cognitive Radios in Dynamic Spectrum Access Networks*, M.Sc. Thesis, Department of Electrical Engineering & Computer Science, Jawaharlal Nehru Technological University, India, 2007.
- [17] A. Zubow and R. Sombrutzki, "Adjacent Channel Interference in IEEE 802.11n," in the 2012 IEEE Wireless Communications and Networking Conference (WCNC), pp. 1163-1168, 2012.
- [18] S. Brandes, I. Cosovic and M. Schnell, "Techniques for Reducing Out-of-band Radiation in OFDM-Based Transmission Systems," *European Transactions in Telecommunications*, vol. 21, p. 11, March 2010.

- [19] S. Technote, "Communication - OFDM, ", [Online], Available: http://www.sharetechnote.com/html/Communication_OFDM.html.
- [20] A. D. S. Jayalath and C. Tellambura, "Reducing the Out-of-band Radiation of OFDM Using an Extended Guard Interval," in the 54th IEEE Vehicular Technology Conference (VTC), pp. 829-833, vol. 2, 2001.
- [21] I. Cosovic, S. Brandes and M. Schnell, "Subcarrier Weighing: A Method for Sidelobe Suppression in OFDM Systems," IEEE Communications Letters, pp. 444-446, vol. 10, 2006.
- [22] S. Pagadarai, R. Rajbanshi, A. M. Wyglinski and G. J. Minden, "Sidelobe Suppression for OFDM-Based Cognitive Radios Using Constellation Expansion," in the IEEE Wireless Communications and Networking Conference, pp. 888-893, 2008.
- [23] J. G. Proakis, Digital Communications, 4th Ed., London: McGraw-Hill, 2001.
- [24] K. Pahlavan and P. Krishnamurthy, Principles of Wireless Networks: A Unified Approach, Prentice Hall PTR, 2001.
- [25] P. Wang, J. An and Y. Wu, "Reduction of Out-of-band Radiation in OFDM-Based DRM Simulcast Systems," International Conference on Wireless Communications, Networking and Mobile Computing, pp. 1-4, 2006.
- [26] A. W. Mustafa and K. G. Samarah, Adjacent Channel Interference Reduction in OFDM Systems, Unpublished Master Thesis, Electrical Engineering Department, Mutah University, 2017.
- [27] M. D. A. R. Chung, M. Dohler, M. Fiacco, S. Saunders, J. Brown, SMR. Jones, T. Harrold and A. Nix, "Propagation Models Final Report," London, 26 Jan. 2000.

ملخص البحث:

يعد الإرسال المضاعف عن طريق التقسيم الترددي المتعامد تقنية واحدة للإرسال الراديوي. ومع ذلك، إحدى أكبر المشكلات هي الإشعاع العالي خارج النطاق، الذي ينتج عن الفلقات الجانبية للحاملات الفرعية للإرسال المضاعف عن طريق التقسيم الترددي المتعامد؛ التي تعد مصدراً للتداخل من قنوات الإرسال المجاورة.

تركز هذه الورقة على تقليل الإشعاع خارج النطاق من خلال قراءة قدرة الإشعاع في الفلقات الجانبية واستخراجها عبر تمديد إشارة الإرسال المضاعف عن طريق التقسيم الترددي المتعامد في المجال الزمني بواسطة أصفار في الجانبين. ثم بتحويل الإشارة الناتجة إلى المجال الزمني وإزالة العينات الممتدة من أجل الحصول على العدد (N) من العينات من إشارة المجال الزمني التي تمثل إشارة الإشعاع خارج النطاق. ومن ثم إجراء تحويل فورييه للإشارة الناتجة وإزالة الحاملات الفرعية عالية التردد للحصول على أدلة يتم عكسها ثم إضافتها إلى الحاملات الفرعية للبيانات الأصلية، الأمر الذي ينجم عنه التقليل من تداخل القنوات المتجاورة. حيث أن الإشارة المضاعفة تمثل إشارة ضجيج بالنسبة للإشارة المرغوبة، مما يضعف أداء النظام من حيث معدل الأخطاء (BER). لذا، يتم استخدام معامل وزن يطبق على الإشارة المضافة للحصول على أداء أفضل مع تقليل جيد في الإشعاع خارج النطاق. تم استخدام محاكاة عبر (ماتلاب/سيميونك) لتقييم التقنية المقترحة بمعاملات وزن مختلفة وفصل مختلف الترددات بين الإشارة المرغوبة والإشارة المجاورة. فعند تخميد مقداره صفر ديسيبيل للإشارة المضافة، تم الحصول على تقليل للإشعاع خارج النطاق مقداره 10 ديسيبيل. أما عندما يعمل معامل الوزن على تقليل قدرة الإشارة الداخلة بمقدار 3 ديسيبيل، فيتم الحصول على تقليل في الإشعاع خارج النطاق بمقدار 6 ديسيبيل. وفي المحصلة، يتحسن أداء النظام من خلال تطبيق التقنية المقترحة، ويعتمد التحسن على البعد بين تردد الإشارة المرغوبة وتردد الإشارة المجاورة.

